

ENGINEERING DATA SHEET

<i>Inducers</i>		
Date	Supersedes	No.
03/29/99	01/01/71	32E

Inducers have been developed to improve the required net positive suction head requirements for all Chempump Models except GA and GB. (These models have only a 1" suction and an inducer would not be practical.) $NPSH_r$ curves, with and without inducers, are included on the performance curves for each model of pump.

The inducer mounts on the threaded area of the rotor assembly (taking the place of the impeller nut) and operates as a low $NPSH_r$ axial flow impeller in series with the main pump impeller. The inducer can be added to any of the standard models by removing the impeller nut and replacing it with the inducer. This feature will achieve field reduction of the $NPSH_r$ characteristics of the pump. The inducer has a built-in locknut to prevent loosening or spinning-off during rotation check. Hydraulic balance, total dynamic head and capacity are not affected by the inducer and all standard modifications and accessories can be specified on pumps with inducers.

Chempump offers two types of inducers:

Axial Inducers:

This type of inducer reduces the $NPSH_r$ of the pump throughout the entire operating range.

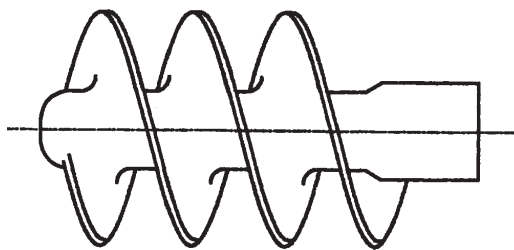
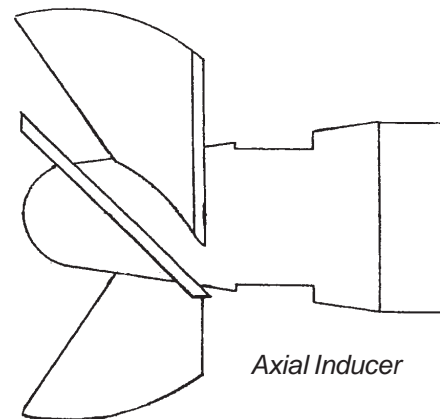

Helical Inducer

Helical Inducer:

This type of inducer will reduce the $NPSH_r$ of a pump for a specific flow range. Outside of the flow range, the $NPSH_r$ may be higher than what is required without an inducer. A helical Inducers will lower the $NPSH_r$ more than an axial inducer for a specific flowrate, but care must be taken that the flow remains within the operating range of this inducer.